

VHPS-NM-1000-AA (MANUAL NARROW MAST HYDRAULIC HAND PUMP STACKER - ADJUSTABLE FORKS OVER ADJUSTABLE LEGS)

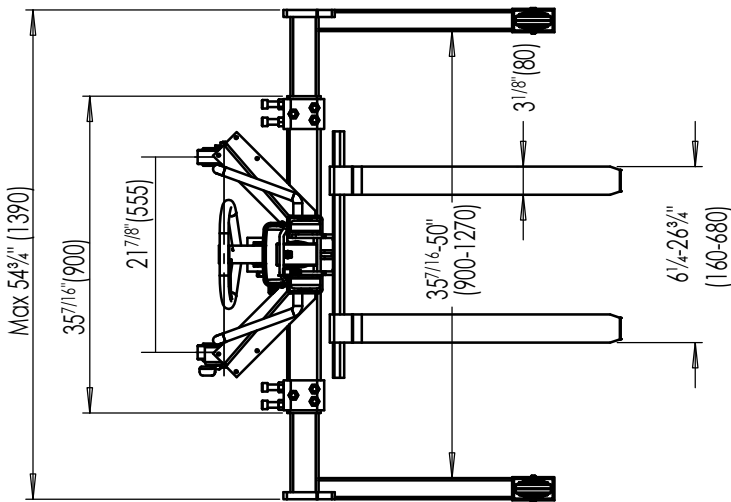
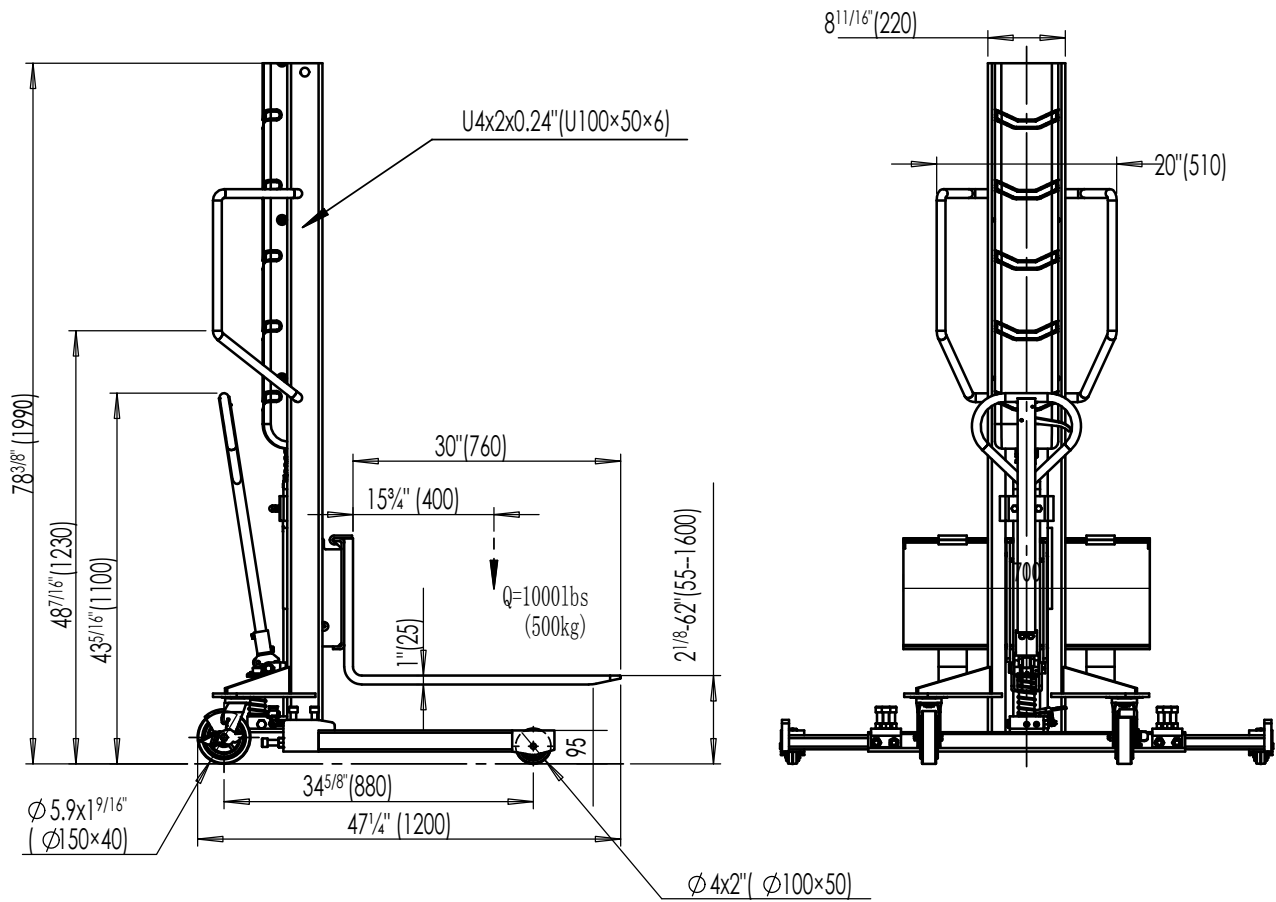

Specifications

- *Model # VHPS-NM-1000-AA
- *Capacity (UDL): 1,000 lbs
- *Lift height: 62"
- *Lowered height: 21 1/8"
- *Adjustable forks & adjustable legs
- *Single mast
- *Number of pumps to raise to maximum height: 74
- *7/8" stroke per pump
- *Down time loaded/unloaded: 20/18 secs
- *Overall mast height: 78"
- *Steering wheel: $\text{Ø}5.9 \times 1 \frac{9}{16}$ "
- *Front wheel: $\text{Ø}4 \times 2$ "

VESTIL MANUFACTURING CORP.

DRAWN BY: TM

DATE: 11/20/18

Reference:

DRWG./FILE NAME:
VHPS-NM-1000-AA